



GEM2006 - PEARL ICE[®] MAKER PEARLSTORM[™]

Ice-O-Matic[®]
Ice. Pure and Simple[®]



Energy Star Certified
on certain models



GEM2006 ON IOD25 ○

Features

- Space-saving 30" (762 mm) wide design.
- Produces up to 2,225 lbs (1,009 kg) of ice per day.
- Soft, chewable nugget ice crystals.
- Cools beverages faster and longer while maintaining flavors better.
- Decreased water and power usage compared to cube ice makers.
- *SystemSafe* load monitoring system constantly checks workload on gearbox, shutting down system before a problem develops and preventing costly repairs.
- Water sensor eliminates low or no water failures and cannot be affected by adverse water conditions.
- Rugged stainless steel evaporators and auger ensures reliability.
- Industrial-grade and maintenance-free roller bearings.
- Heavy-duty gearbox provide years of trouble-free service.

Options & Accessories

WATER FILTERS		
Ice Machine Model	Manifold	
	System	Replacement
GEM2006	IFQ2-XL	IOMQXL (2)

Ice Maker Warranty

Every Ice-O-Matic ice maker is backed by a warranty that provides both parts and labor coverage.

- Three years **Parts** and **Labor** for all Pearl Ice[®] maker parts.
- Five years **Parts** coverage on the compressor.

Ice Form



Bin Chart *Kits for Combining Wider Bins with Smaller Models*

ICE STORAGE BINS									
Model No.	B25	B40	B55	B700	B110	B1000	B1300	B1325	B1600
Capacity	242 lbs (110 kg)	344 lbs (156 kg)	510 lbs (232 kg)	680 lbs (308 kg)	854 lbs (388 kg)	1000 lbs (454 kg)	1320 lbs (599 kg)	1325 lbs (601 kg)	1660 lbs (753 kg)
Width	30 in (762 mm)	30 in (762 mm)	30 in (762 mm)	30 in (762 mm)	48 in (1,219 mm)	48 in (1,219 mm)	48 in (1,219 mm)	60 in (1,524 mm)	60 in (1,524 mm)
Kits	Kit Not Required				BPF-1	Kit Not Required			

See Ice-O-Matic Price List for Adapter Kits to combine ice makers with most available ice/beverage dispensers.

PEARL ICE[®] DIMENSIONS

H x Dia. (in.)	1/2 x 3/8
H x Dia. (mm)	12.7 x 9.5



GEM2006 PEARL ICE[®] MAKER – PEARL STORM[™]

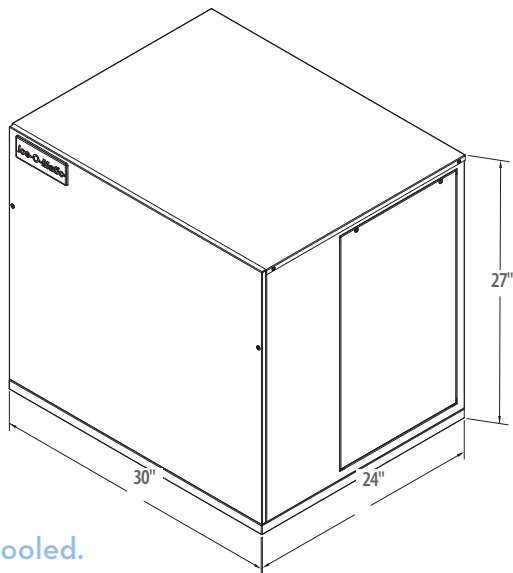

Remote Cooled.

- A. Ice maker water in, 3/8" FPT.
- B. Ice maker water out, 3/4" FPT.
- C. Electrical inlet.
- D. Liquid line, 3/8" male coupling for precharged line set (remote only).
- E1. Discharge line, 1/2" male coupling for precharged line set (remote only).
- E2. Condenser water in, 3/8" FPT (water only).
- F. Remote condenser junction box (remote only).
- G. Condenser water out, 1/2" FPT (water only).

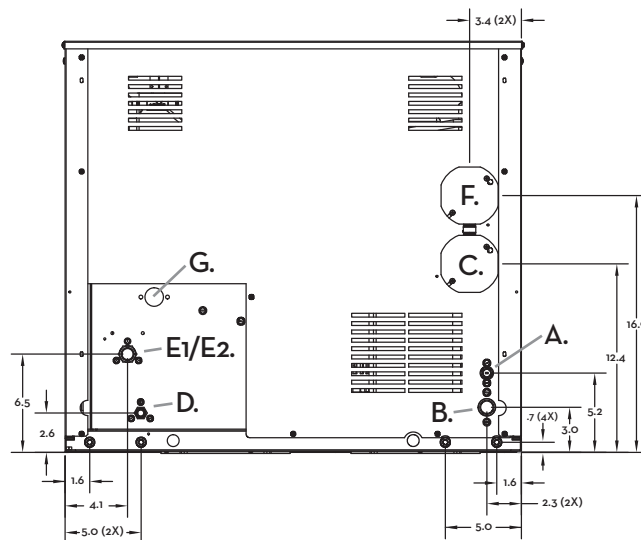

Rear View Water Cooled and Remote Option

Operating Requirements

	MINIMUM	MAXIMUM
		60 Hz
Ambient Temp. Range Air	50°F (10°C)	100°F (38°C)
Water Temp.	40°F (4.4°C)	
Water Pressure	20 PSIG (1.4 BAR)	120 PSIG (8.3 BAR)
Remote Cond. Temps	-20°F (-29°C)	120°F (50°C)

Dimensions

ALL MODELS	
W x D x H (in.)	30 x 24 x 27
W x D x H (mm)	762 x 610 x 686

Specifications

Model Number	Cond. Unit	Ice Production per 24hrs		Water Usage gallons per 100 lbs (45 kg) of Ice 90°F (32°C) air/70°F (21°C) water		kWH Used per 100 lbs (45 kg) of ice @ 90°F (32°C) air/70°F (21°C) water	Voltage Characteristics	Min. Circuit Ampacity	Max Breaker Size	Approx. BTUs per hour**
		70°F (21°C) air/50°F (10°C) water lbs (kg)	90°F (32°C) air/70°F (21°C) water lbs (kg)	Potable	Condenser					
GEM2006R*	Remote	1,960 (889)	1,625 (737)	12.0	-	3.4	208-230/60/1	24.0	40	17,030
GEM2006W	Water	2,225 (1,009)	1,785 (809)		84	3.0		23.0	35	

*Requires **RC306C40** (replaces RCA2061) Remote Condenser.
 **BTUH is calculated 0°F Evaporator, 110°F Condensing, and 33 PSIG.
 When installing a modular GEM on a drink dispenser, the **KGEMDISP MUST** be used.

NOTES:
 Number of Wires: 3 (including ground)
 Approx. Shipping Weight lbs (kg): GEM2006R 316 (143) • GEM2006W 316 (143)
 Refrigerant Type: R404A

Ice-O-Matic reserves the right to change the specifications at any time without obligation. Certifications may vary depending on country of origin.

GEM2006 PEARL ICE® MAKER — PEARL STORM™